

Communicating the science of climate change

Richard C. J. Somerville and Susan Joy Hassol

Citation: *Physics Today* **64**, 10, 48 (2011); doi: 10.1063/PT.3.1296

View online: <https://doi.org/10.1063/PT.3.1296>

View Table of Contents: <https://physicstoday.scitation.org/toc/pto/64/10>

Published by the [American Institute of Physics](#)

ARTICLES YOU MAY BE INTERESTED IN

[Science controversies past and present](#)

Physics Today **64**, 39 (2011); <https://doi.org/10.1063/PT.3.1295>

[Networks: An Introduction; Networks, Crowds, and Markets: Reasoning About a Highly Connected World](#)

Physics Today **64**, 54 (2011); <https://doi.org/10.1063/PT.3.1297>

[Climate change impacts: The growth of understanding](#)

Physics Today **68**, 46 (2015); <https://doi.org/10.1063/PT.3.2914>

[How to deal with climate change](#)

Physics Today **67**, 32 (2014); <https://doi.org/10.1063/PT.3.2548>

[Land's complex role in climate change](#)

Physics Today **69**, 40 (2016); <https://doi.org/10.1063/PT.3.3364>

[Cause and Effect in Global Warming](#)

Physics Today **58**, 14 (2005); <https://doi.org/10.1063/1.4796704>

1000 QUBITS AS EASY AS 1
WITH THE MOST ADVANCED
QUANTUM CONTROL STACK

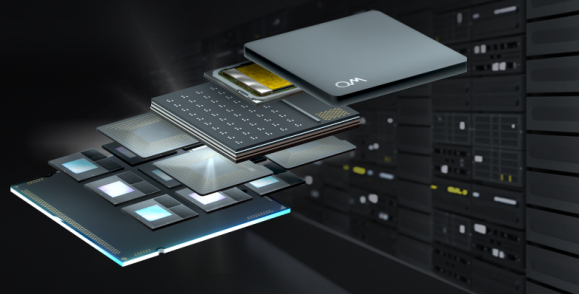

Communicating the science of climate change

Richard C. J. Somerville and Susan Joy Hassol

It is urgent that climate scientists improve the ways they convey their findings to a poorly informed and often indifferent public.

Richard Somerville (<http://www.richardsomerville.com>) is a professor at the Scripps Institution of Oceanography, University of California, San Diego, and the science director of Climate Communication, a nonprofit project based in Boulder, Colorado (<http://www.climatecommunication.org>). **Susan Joy Hassol**, who works with climate scientists to communicate what they know to policymakers and the public, is the director of Climate Communication.

Over the past half century, the powerful new science of climate and climate change has come into being. Research during that period has settled a fundamental climate question that had challenged scientists since the 19th century: Will human beings, by adding carbon dioxide and other heat-trapping gases to the atmosphere, significantly affect climate? The answer, debated for decades, is now known to be yes. Scientists now understand clearly that humankind is no longer a passive spectator at the great pageant of climate change. They have established that the climate is indeed warming and that human activities are the main cause.¹ Every year brings thousands more research papers containing new knowledge of the many aspects of climate change.

Public perception

Climate researchers know that the case for human-induced climate change has become stronger, more compelling, and increasingly urgent with each passing year. Yet in some countries, notably the US, the proportion of the public and policymakers who reject the science has grown. For example, though the evidence of global warming is unequivocal, a new study by a team from Yale and George Mason universities shows that as of May 2011, only 64% of Americans think the world is warming (down from a high of 71% percent in November 2008). And only 47% of all respondents believe that global warming, if it exists, is caused mostly by human activity.² A related study by the Yale–George Mason team classified the US public into “global warming’s six Americas.”³ Fig-

ure 1 shows those categories and the team’s most recent breakdown of the public into them. Only in the *alarmed* and *concerned* categories do majorities understand that the observed warming is caused by human activity.

Americans are also unaware of the strength of the scientific consensus. At least 97% of climate researchers most actively publishing in the field agree that climate change is occurring and that it is primarily human-induced.⁴ But that strong consensus is largely unrecognized by the public. Only 39% believe that most scientists think global warming is occurring, and 40% believe there is a lot of disagreement among scientists about whether it’s occurring. Even among those in the most engaged categories of figure 1, only 44% of the *alarmed* and 18% of the *concerned* say there is scientific agreement that the world is warming. Among the *disengaged*, *doubtful*, and *dismissive*, less than 5% believe there is such agreement.

Other misconceptions are rampant among Americans. For example, many people confuse climate change with the ozone hole. They incorrectly identify the ozone hole, aerosol spray cans, toxic waste, nuclear power, and the space program as causes of global warming.⁵

Why the confusion?

There are many reasons for the large-scale public confusion. (See the article by Steven Sherwood on page 39.) Acceptance of the science of climate change appears to track with the strength of the economy. In difficult times, people seem more likely to reject the science. That may be because they believe



that policies for addressing the problem might harm the economy. And perhaps people can only worry about so many things at a time.

A second major factor is the well-organized and well-funded disinformation campaign that has been waged against climate science for decades. As documented in numerous books, the campaign seeks to sow doubts about the science.^{6,7} Motivations for that campaign range from ideological to financial. Some fear that policies to address climate change will limit individual freedoms and the free market. Some in the oil and coal industries fear for their short-term profits. Among the purveyors of the disinformation are public-relations masters who have succeeded in crafting simple, clear messages and delivering them repeatedly. The public's failure to perceive the scientific consensus seems to reflect the success of that campaign.

It helps the disinformation campaign that a small number of climate scientists disagree with the widely accepted central findings of the field. That there are a few dissenters is not surprising; all areas of science have outliers. But the mainstream scientific conclusion that climate change is occurring and is mostly human-induced has been endorsed by professional societies and science academies worldwide.⁸

A third factor is widespread scientific illiteracy, which is related to the fact that people trust and believe those with whom they share cultural values and worldviews. Opinion leaders who espouse the notion that global warming is a hoax are, for some people, trusted messengers. A fifth factor is that for most of human history, people have seen weather as the province of God, and some simply cannot accept the idea that humans could affect it. We still call weather disasters "acts of God."

Yet another factor is the way the media handle the topic. They often portray climate change as a controversy, presenting the opposing sides as equally credible. The current crisis in journalism has also resulted in fewer experienced reporters with the requisite expertise, which leads to coverage that can be inept and misleading.

Not least important is how scientists communicate—or fail to do so. Reasons for that failure include what scientists talk about as well as how they talk about it. Narrative skills help reach people. Effective communication is usually not a lecture but a conversation that involves what people really care about. People generally care less about basic science than about how climate change will affect them and what can be done about it. Furthermore, climate change is often framed as an environmental issue, when it should more appropriately be framed as an issue threatening the economy and affecting humanity's most basic needs: food, water, safety, and security.

For all those reasons, despite remarkable scientific advances, many people still do not realize, or do not accept, what climate scientists have discovered.⁶ The strong consensus in the expert community is not widely appreciated. There is a disturbingly large gulf between the research community's knowledge and the general public's perception. Recent polling data reveal that many Americans "would most like to have an expert explain how experts know that global warming is happening and is caused by human activities" (reference 3, page 6).

The IPCC

For mainstream climate scientists, the answers to those fundamental questions about the reality and causation of climate change are already well established. They are discussed and explained in detail in many reports, especially the Working

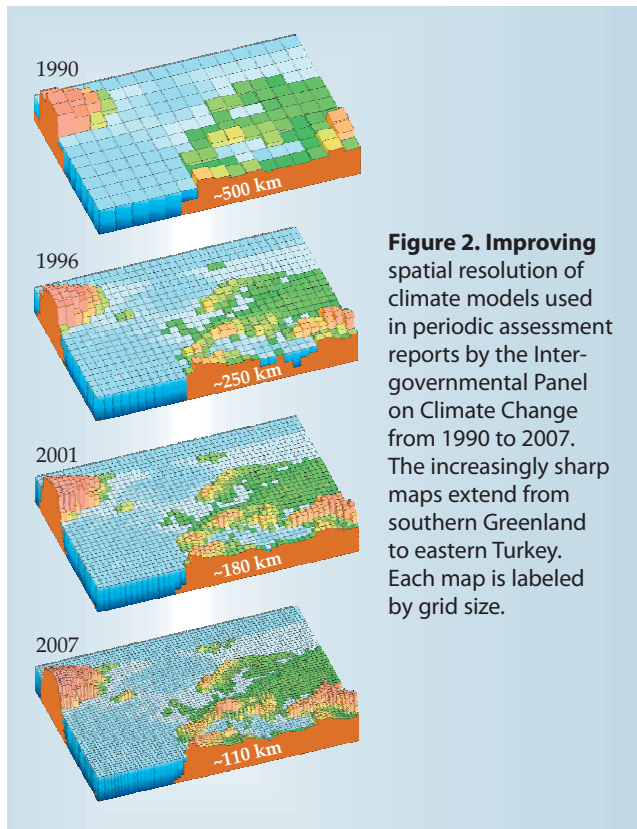

Figure 2. Improving spatial resolution of climate models used in periodic assessment reports by the Intergovernmental Panel on Climate Change from 1990 to 2007. The increasingly sharp maps extend from southern Greenland to eastern Turkey. Each map is labeled by grid size.

Group I portion of the 2007 Fourth Assessment Report of the Intergovernmental Panel on Climate Change (IPCC). That document assesses the physical-science foundation for our understanding of climate change. It is based on careful consideration of the entire body of relevant published research studies. Its main findings are summarized in two key statements:¹

Warming of the climate system is unequivocal, as is now evident from observations of increases in global average air and ocean temperatures, widespread melting of snow and ice, and rising global average sea level. (page 5)

Most of the observed increase in global average temperatures since the mid-20th century is *very likely* due to the observed increase in anthropogenic greenhouse gas concentrations. (page 10)

The IPCC is a link between climate change science and public policy. Its mandate is to provide policymakers with reliable and intelligible scientific information and to assess climate change science in an open and objective manner that is policy relevant but not policy prescriptive. The IPCC doesn't carry out research. It simply assesses the research performed and published by scientists throughout the world. The panel organizes large numbers of scientists to perform the assessments and write the reports. The successive IPCC reports have expressed increasing certainty that human activity is the main cause of the observed climate warming.⁹

Discovery of a few errors in the 2007 IPCC Fourth Assessment Report tarnished the reputations of both the IPCC and climate scientists. In a report of some 3000 pages, one expects some minor errors, even after extensive reviewing. The IPCC has since revised and strengthened its procedures so as to increase transparency and accountability, and to reduce the likelihood of error. The fundamental conclusions of the

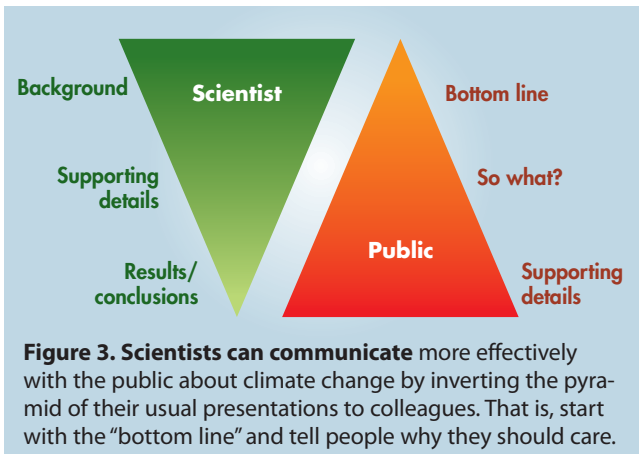

Figure 3. Scientists can communicate more effectively with the public about climate change by inverting the pyramid of their usual presentations to colleagues. That is, start with the “bottom line” and tell people why they should care.

IPCC reports are unaffected by any errors, and they remain unchallenged within the mainstream research community.

The online publication in 2009 of stolen emails written by prominent climate scientists promptly led to publicized accusations of data tampering and other wrongdoing. But numerous subsequent investigations have exonerated the accused researchers. They committed no fraud and no scientific misconduct.

These two episodes illustrate several of the factors that contribute to public confusion. The disinformation campaign seized on the incidents to skillfully and repeatedly denounce both the IPCC and climate scientists. Neither the scientists nor the panel were very effective in refuting the attacks. In the media, the initial accusations were prominently featured, but little attention was given to the trivial nature of the IPCC errors or to the outcome of the investigations that cleared the scientists. These events provide a teachable moment: They illustrate how important it is that the scientific community improve its efforts at communicating climate change science.

Climate models

Modern global climate models are essential tools for determining the cause of recent warming as well as for developing projections of future climate change.¹⁰ A key component of the models is their ability to simulate realistically many aspects of climate. A half century of model development has led to a suite of global climate models that have become ever more comprehensive physically. Figure 2 shows improvement in their spatial resolution over the past two decades.¹¹

Many kinds of observations have demonstrated that the climate is warming. Atmospheric temperatures are measured at surface sites and by networks of balloon-borne instruments and satellites. Those data all show warming. Ocean temperatures are measured from ships, satellites, buoys, and subsurface floats. All show warming. In fact, most of the heat added to the climate system in recent decades is in the ocean. Sea level is rising globally. Mass loss from glaciers, Arctic sea ice, and the ice sheets on Greenland and Antarctica also indicate a warming climate.

An entire branch of climate science, known as detection and attribution, is devoted to determining whether any particular class of observations represents a significant departure from natural variability and, if so, to identifying the cause. “Detection” here refers to the task of distinguishing changes in climate due to some external cause from changes that could be expected from known modes of natural climate variability such as El Niño and La Niña.

For changes not compatible with natural variability, “attribution” denotes the task of determining what external fac-

tor is responsible. Extensive research has shown that the dominant observed changes in the climate system are consistent with the responses expected from increasing amounts of greenhouse gases in the atmosphere. They are inconsistent with any natural external forcing mechanisms such as volcanism or changes in the Sun. The fingerprint of human activity is thus clearly revealed in the magnitude and pattern of the observed climate changes.

Another good example of recent progress in climate science is our improved understanding of the increase in sea level to be expected as Earth continues to warm. Sea levels rise in a warming world for several distinct reasons. One is simple thermal expansion of ocean water. Another is melting glaciers, and a third is the contribution from the melting of the gigantic ice sheets on Greenland and Antarctica.

The 2007 IPCC report projected a global average rise in sea level of 18–59 cm by the end of this century, depending on different models and different scenarios for greenhouse gas emissions. The report stressed that thermal expansion contributed 70–75% of the central estimates for all the scenarios. It warned that melt water from the Antarctic and Greenland ice sheets might contribute significantly to sea-level rise. But the report’s quantitative projections did not include those contributions because “understanding of these effects is too limited to assess their likelihood or provide a best estimate” (reference 1, page 14).

In the years since 2007, however, climate science has advanced.¹² New technology has been brought to bear. For example, the *GRACE* (*Gravity Recovery and Climate Experiment*) satellites, launched in 2002, have used tiny variations in Earth’s gravity to infer changes in the masses of the Antarctic and Greenland ice sheets. Several years of *GRACE* results and other data now show conclusively that both ice sheets are losing mass and contributing to global sea-level rise. The physical processes involved in mass loss are complex; they include surface melt, glacier flow, and snowfall. Much remains to be learned.

Greenland and Antarctica differ in important respects. But the contributions of both to sea-level rise are clearly increasing with time. If recent trends continue, their ice-sheet losses are expected to dominate global sea-level rise before the century ends. This century’s sea-level rise is now estimated by some researchers to be as great as 1 to 2 meters.¹² Such conclusions must be effectively communicated to policymakers and the public.

Better communication

If wise climate policy is to be informed by the best and most up-to-date climate science, scientists have a critical role to play in communicating their findings to the wider world. But scientists are used to communicating with their peers in a certain format, beginning with background information, moving to supporting details, and finally coming to their results and conclusions. For communicating with the public, however, they must invert that pyramid and begin with the bottom line, as shown in figure 3. People also want to know why they should care—the “so what” question.

Scientists typically fail to craft simple, clear messages and repeat them often. They commonly overdo the level of detail, and people can have difficulty sorting out what is important. In short, the more you say, the less they hear. And scientists tend to speak in code. We encourage them to speak in plain language and choose their words with care (see figure 4). Many words that seem perfectly normal to scientists are incomprehensible jargon to the wider world. And there are usually simpler substitutes. Rather than “anthro-

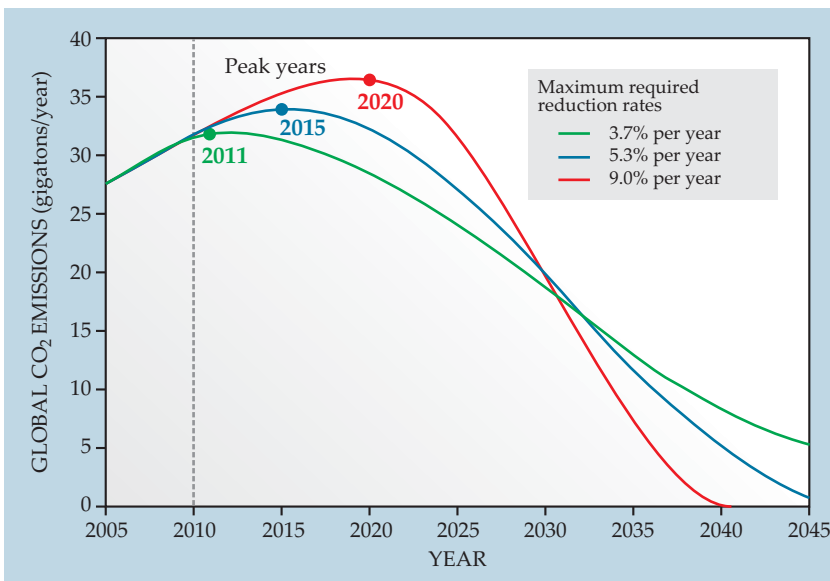

Figure 5. Three scenarios, each of which would limit the total global emission of carbon dioxide from fossil-fuel burning and industrial processes to 750 Gt over the period 2010–50. If emissions remain negligible after 2050, that limit yields an estimated 67% probability of capping global warming at 2° C above preindustrial temperatures.¹² As indicated by the color-keyed table, the later the year of peak emission, the higher would have to be the maximum rate of annual reduction, which would begin in the early 2030s. (Adapted from German Advisory Council on Global Change factsheet 2/2009.)

belief. The conclusion that the world is warming and that humans are the primary cause is based on facts and evidence. Even the term “consensus” makes some in the public conclude that global warming is just a matter of opinion. When scientists say human activity “contributes” to global warming, that sounds like it could be a small contribution, when in fact it is the primary cause. When they say that climate change is due, “at least in part,” to humans, or that “natural factors alone” could not have caused the observed warming, they reinforce the misconception that humans are perhaps a small part of the problem.

When climate scientists say that warming is “inevitable,” it can give the impression that nothing can be done. Of course, that’s not what they’re saying, but they should be careful to make clear that society faces choices. Although it is true that some additional warming cannot be avoided, the amount of future warming is still largely in our hands. Lower emissions of greenhouse gases will lead to less warming and less severe impacts.

Climate scientists have also developed a lexicon of likelihood terms (likely, very likely, and so forth) to roughly quantify the probability of particular outcomes. The overuse of such terms gives the impression that they know much less than they actually do. The public interprets those terms to imply much greater uncertainty than scientists intend to convey.¹⁴

Consider what your audience cares about. Talk more about the local impacts of climate change that are happening now. Connect the dots between climate change and what people are experiencing, such as increases in extreme weather. Try to craft messages that are not only simple but memorable, and repeat them often. Make more effective use of imagery, metaphor, and narrative. In short, be a better storyteller, lead with what you know, and let your passion show. Such communication skills can be taught, developed, and practiced. Make use of more effective outreach strategies such as partnering with other messengers and connecting with audiences on values you share with them.

Deciding the future climate

The urgency of taking action to limit manmade climate change combines subjective considerations with scientific ones. That’s not widely appreciated, though the relevant science is quite clear. The science tells us that once a political de-

cision is taken to limit global warming to some specified level, meeting that goal requires that the total manmade emission of CO₂, integrated over time from the Industrial Revolution to the foreseeable future, must be correspondingly limited. This conclusion follows from the long atmospheric residence time of CO₂ and the fact that the level of warming depends on the total amount of heat-trapping gases in the atmosphere. So, unless practical means are found to remove large amounts of CO₂ from the atmosphere, annual emissions must eventually go virtually to zero because the integrated total is limited to a specific finite amount.

That maximum amount, for a given temperature ceiling, can now be estimated from our knowledge of the sensitivity of climate to atmospheric CO₂. The longer we wait to begin decreasing emissions, the faster the rate of decrease must be. That’s the message of figure 5, which shows several possible scenarios for limiting global warming to an average of 2° C above preindustrial temperatures.¹²

Governments can decide what level of climate change they regard as tolerable. That choice can be informed by science, but it will also be affected by risk tolerance, values, politics, priorities, and economics. In the end, it is a choice that humanity as a whole, acting through governments, has to make.

The choice that has thus far received the most support is to limit global warming to 2° C. That target has been formally adopted by the European Union and supported by many other countries. Some recent research suggests that severe climate change, including very large sea-level rises, can occur even with a 2° C ceiling. But that topic is beyond the scope of this article.

If governments agree on the 2° C rise as a tolerable upper limit, what does climate science have to say about the steps that will be required to keep climate change within that limit? The conclusions illustrated in figure 5 show that in order to have a reasonable likelihood of meeting the 2° C target, global CO₂ emissions must peak and then start falling rapidly within the next 5–10 years, approaching zero by midcentury. The urgency is not ideological; it’s dictated by the physics and geochemistry of the climate system.

The science tells us that meeting the policy goals requires urgent action. But given the limited public understanding, the need for scientists to communicate better also becomes urgent. Many scientists have expressed interest in communi-

cating climate change science. Workshops aimed at improving those communication skills are increasingly popular at professional-society meetings and other venues.

We must find ways to help the public realize that not acting is also making a choice, one that commits future generations to serious impacts. Messages that may invoke fear or dismay—as projections of future climate under business-as-usual scenarios often do—are better received if they also include hopeful components. Thus we can improve the chances that the public will hear and accept the science if we include positive messages about our ability to solve the problem. We can explain, for example, that it's not too late to avoid the worst; lower emissions will mean reduced climate change and less severe impacts. We can point out that addressing climate change wisely will yield benefits to the economy and the quality of life. We can explain, as figure 5 shows, that acting sooner would be less disruptive than acting later. Let us rise to the challenge of helping the public understand that science can illuminate the choices we face.

References

1. S. Solomon et al., eds., *Climate Change 2007: The Physical Science Basis—Contribution of Working Group I to the Fourth Assessment Report of the Intergovernmental Panel on Climate Change*, Cambridge U. Press, New York (2007), available at <http://www.ipcc.ch>.
2. A. Leiserowitz et al., *Climate Change in the American Mind: Americans' Global Warming Beliefs and Attitudes in May 2011*, Yale Project on Climate Change Communication, New Haven, CT (2011), available at <http://environment.yale.edu/climate/files/ClimateBeliefsMay2011.pdf>.
3. A. Leiserowitz et al., *Global Warming's Six Americas in May 2011*, Yale Project on Climate Change Communication, New Haven, CT (2011), available at <http://environment.yale.edu/climate/files/SixAmericasMay2011.pdf>.
4. W. R. L. Anderegg et al., *Proc. Natl. Acad. Sci. USA* **107**, 12107 (2010).
5. A. Leiserowitz, N. Smith, J. R. Marlon, *Americans' Knowledge of Climate Change*, Yale Project on Climate Change Communication, New Haven, CT (2010), available at <http://environment.yale.edu/climate/files/ClimateChangeKnowledge2010.pdf>.
6. N. Oreskes, E. M. Conway, *Merchants of Doubt: How a Handful of Scientists Obscured the Truth on Issues from Tobacco Smoke to Global Warming*, Bloomsbury Press, New York (2010).
7. R. Gelbspan, *Boiling Point: How Politicians, Big Oil and Coal, Journalists, and Activists Have Fueled the Climate Crisis—and What We Can Do to Avert Disaster*, Basic Books, New York (2004); R. Gelbspan, *The Heat Is On: The Climate Crisis, the Cover-up, the Prescription*, Perseus, Cambridge, MA (1998); J. Hoggan, *Climate Cover-Up: The Crusade to Deny Global Warming*, Greystone Books, Vancouver, BC, Canada (2009).
8. R. C. J. Somerville, in *The Development of Atmospheric General Circulation Models: Complexity, Synthesis and Computation*, L. Donner, W. Schubert, R. Somerville, eds., Cambridge U. Press, New York (2011), p. 225.
9. B. Bolin, *A History of the Science and Politics of Climate Change: The Role of the Intergovernmental Panel on Climate Change*, Cambridge U. Press, New York (2007).
10. P. N. Edwards, *A Vast Machine: Computer Models, Climate Data, and the Politics of Global Warming*, MIT Press, Cambridge, MA (2010).
11. L. Donner, W. Schubert, R. Somerville, eds., *The Development of Atmospheric General Circulation Models: Complexity, Synthesis and Computation*, Cambridge U. Press, New York (2011).
12. I. Allison et al., *The Copenhagen Diagnosis: Updating the World on the Latest Climate Science*, Elsevier, Burlington, MA (2011). An earlier edition is available at <http://www.copenhagendiagnosis.com>.
13. S. J. Hassol, *Eos Trans. Am. Geophys. Union* **89**, 106 (2008), available at <http://www.climatecommunication.org>.
14. D. V. Budescu, S. Broomell, H.-H. Por, *Psycholog. Sci.* **20**, 299 (2009).
15. One can create such word clouds at <http://www.wordle.net>. ■

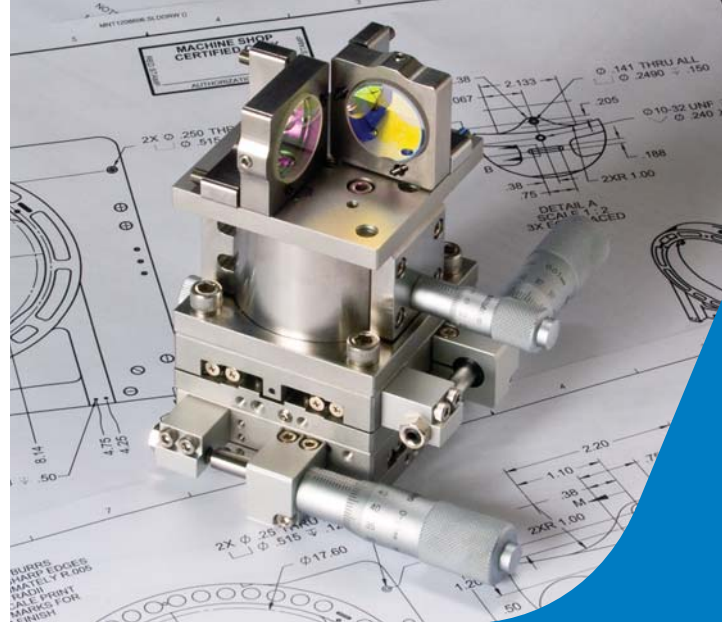

UNDER PRESSURE TO FIND STABLE MOUNTS?

Custom Solutions for any Atmosphere.

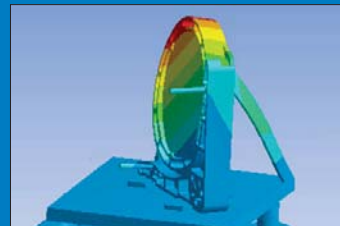

18 inch mirror mount
Vibrational stability

- Vacuum compatible actuators
- Thermal and Vibrational analysis
- Mounted optics flatness testing
- Special cleaning and packaging
- Cleanroom assembled and tested
- Size 12 to 450 mm

For more information go to:
cvmellesgriot.com/Vacuum

CVI Melles Griot
AllThingsPhotonic.com

Lasers | Lenses | Mirrors | Assemblies
Windows | Shutters | Waveplates | Mounts

Americas +1 505 296 9541

Europe +31 (0)316 333041

Asia +81 3 3407 3614